

Part number

CHP 24 CS

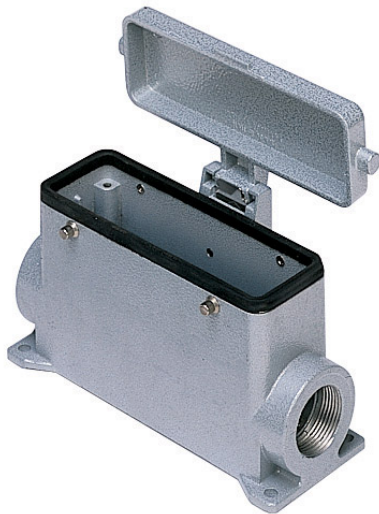

Brief description:

surface mounting housings with 4 pegs, size "104.27", metal cover, Pg21, metal version, IP65

Product description

Version	metal version
Series	Surface housings, with 4 pegs
Product type	with 4 pegs and gasket
Variant	metal cover
Family	CLASS enclosures
Size	size "104.27"

Technical data

Operating temperature range (min, max)	-40°C ... +125°C
Material	metal
IP degree of protection	IP65
Cable entry	Pg21

Further technical details

Weight	387,00 g
--------	----------

Approvals / Standards

Quality mark	 (type:4/4X/12),  , EAC
Conformity	CQC, CE

General ordering information

EAN13 code	8015747022477
Tariff number	85369095

Packaging Information

Packaging weight	4,10 kg
Packaging volume	17,10 dm ³
Packaging description	Carton box
Packaging quantity	10 Pcs
Packaging EAN code	8015747022484
Sub-packaging weight	2,05 kg
Sub-packaging description	Carton Box
Sub-packaging quantity	5 Pcs
Sub-packaging EAN barcode	8015747022491

Part number

CHP 24 CS



Catalogue drawings

CHP CAP - MHP MAP

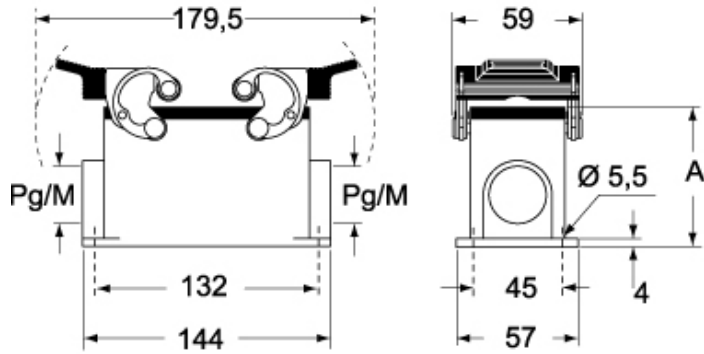

CHP CS/CP CAP CS/CP - MHP CS/CP MAP CS/CP

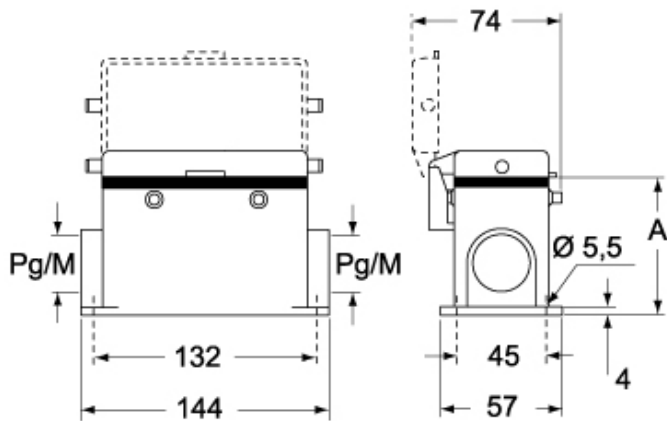

	A
CHP / MHP	63
CAP / MAP	80
CHP CS / MHP CS	63
CAP CS / MAP CS	80
CHP CP / MHP CP	63
CAP CP / MAP CP	80